

## NAP NEGRA 2 IN 16H CON SC/APC SIN PLC

**MODELO** PB-0216B



### Product Description:

#### 1、 Product Size

300\*270\*95mm

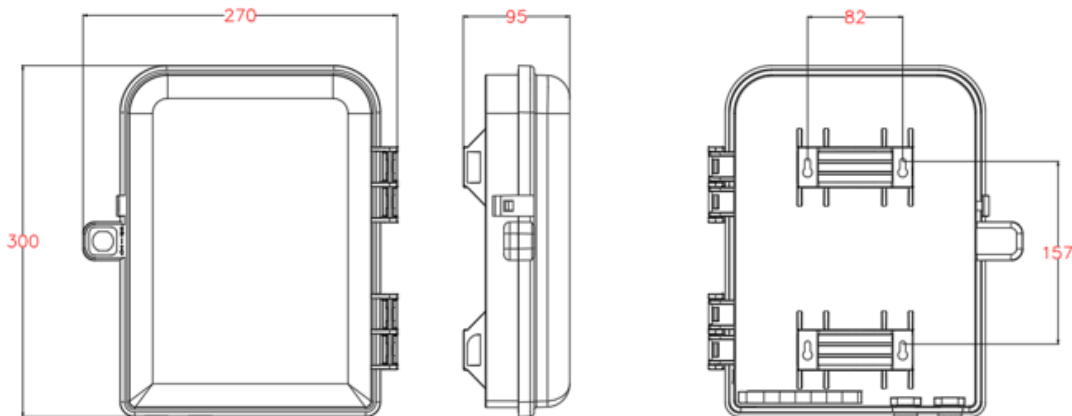

#### 2.-Material

- 2.1 Cabinet material: PC+ABS
- 2.2 Color: Gray
- 2.3 Adapter: SC
- 2.4 Density: 1.18g/cm<sup>3</sup>
- 2.5 Shrinkage rate: 0.50~0.70%
- 2.6 Tensile Modulus: 2700Mpa
- 2.7 Flame retardant grade: UL94V1 or more
- 2.8 Metal Parts had past 48 hours salt spray test

#### 3.-Mechanical capacity

- 3.1 Tension: 500N/1min
- 3.2 Wafering: 200N/100mm
- 3.3 Bending: 150N/±45°/3cycles
- 3.4 Torsion: 50N±90° /3 cycles

## 4.-Electrical Performance

4.1 InsulatedResistance:2\*MΩ/500V

4.2 Voltage withstanding stress:3kV/1min/10mA

## 5.-Box Features

5.1 Protects and manages cable effectively

5.2 Secured with anti-theft locking mechanism

5.3 Good properties of dust, and moisture proofing,IP65

5.4 Clamping for feeder cable and drop cable, fiber splicing, fixation,storage, distribution...etc all in one

5.5 Walland pole mountable (accessories optional)

5.6 Suitable for both outdoor and indoor use

## 6.-Technical parameters

6.1Working temperature : -25°C ~+55°C(indoor)  
-40°C~+85°C(outdoor)

6.2 Relative humidity: 25%~75% (+30°C)

6.3 Installation method: wall-mounted orpole-mounted

6.4 Life time: More than 20years

## 7.-Packing

7.1 1set/box

7.2 10box/carton

## 8.-Picture

